

## Tapping unit with pneumatic feed quill



## CR 14

Maximum drilling capacity in steel (700 N/mm <sup>2</sup> )	M12
Revolutions range (50 Hz)	304-7250 r.p.m.
Maximum turning torque	35 Nm.
Spindle Cone	B-16, TR16, ER-20
Weight (without motor)	~55 Kg.
Available motors (50 Hz)	1.000 r.p.m. / 1.1 Kw. 1.500 r.p.m. / 1.5 Kw. 3.000 r.p.m. / 2.2 Kw.

[ THERE ARE OTHER POSSIBLE COMBINATIONS, PLEASE CONSULT ]

## DIMENSIONS

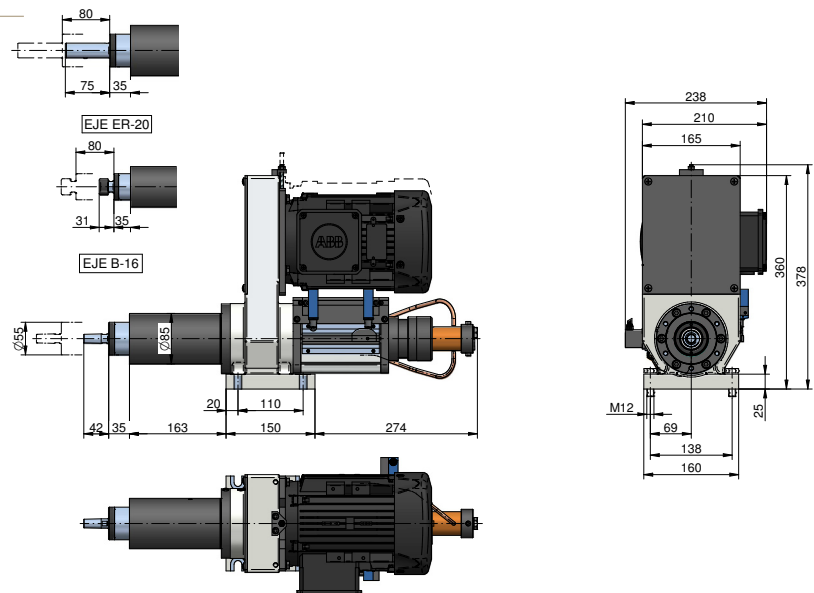

## COMBINABLE ELEMENTS



VH Multispindle head



Tool holder

\* Measures can vary without previous notice. Ask for the updated drawing in every case.